

LCD Screen Packing Machine

Operational Manual

RUIAN ANGHUA MACHINERY CO., LTD

1. Performance and Applicatio

This machine adopt the latest advanced technology and appropriate improvement. The microcomputer chip is the most advanced in the world with both Chinese and English edition, and operation interface of intelligent fault diagnosis. Assembled with photoelectric tracking system, ensure accurate sealing and cutting, automatic completing process of bag making, measuring, filling, sealing and cutting, etc. It is easy to operate, and it is the latest generation of ideal packaging machinery.

2. Technical features and advantages

Linear bearing are adopted for linear bearing and casting mechanical parts, make the machine run stably and durability.

Electrical components are adopted for high-performance chip, fully automatic measure of packing length, without manual adjustment of packaging film length, instead of a function of photo tracking location for color calibration. Conversing from Chinese to English edition, intelligent fault diagnosis and display error location (such as photoelectric error, distance of travel error, etc.). Adjust the fine vibrating strength in front and back, the stuff feeding can be more accurate.

Appropriate packaging materials: with a polyethylene heat sealing layer of compound plastic film, paper, aluminum foil composite film, etc.

There should be printed the black tags of photoelectric control on the side of the packaging material, the width of tags must be more than 5 mm, the length of tags must be more than 10 mm. The sideband printing tags are not allowed to print any other words or logo again, avoid cause error action.

3.Main structure and working principle

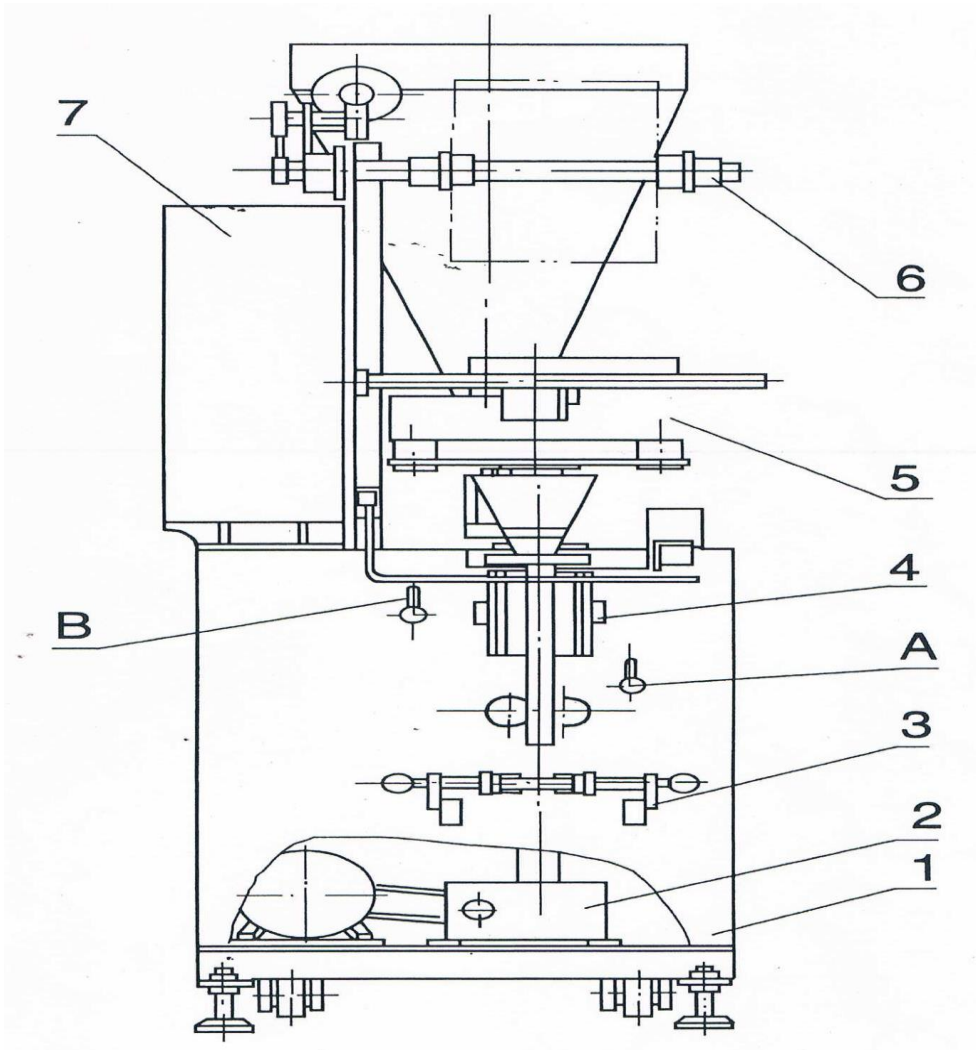

Figure 1、 Profile structure chat

1、 Main structure of machine: frame 1, Transmission mechanism 2, Horizontal seal 3, Longitudinal seal 4, The feeding device (The powder machine is the hopper and the screw, the pellet machine is the turntable) 5, Film feeding mechanism 6, Electric control box 7, etc.

2、 In the figure, the A is a pull film opening and closing handle; the B is a rotary clutch control handle.

3、 In the figure 1, A is the handle of switch film wheel for On or Off; B is the control handle for the wheel clutch.

4、 Working principle:, Material pouring and discharging mechanism, then go into the internal organs of the former, again sent to packaging, bag which have vertical sealed, finally horizontal sealing and cutting, complete packing process.

5、 Electrical system as shown in the electrical schematic diagram, the operation can be achieved by the device installed on the electric control panel (view electrical schematic diagram).

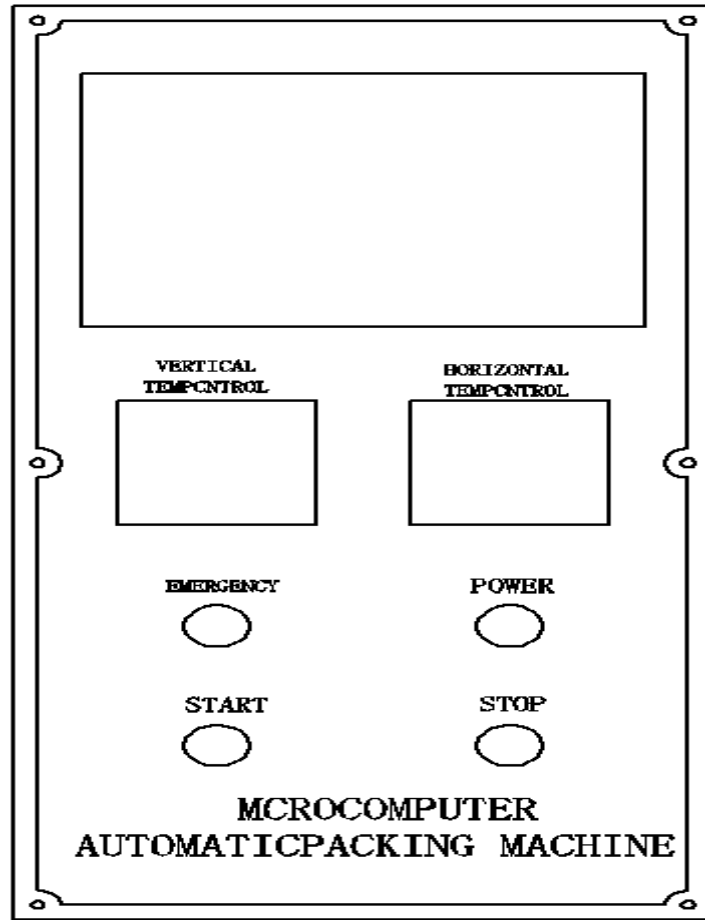

Figure 2

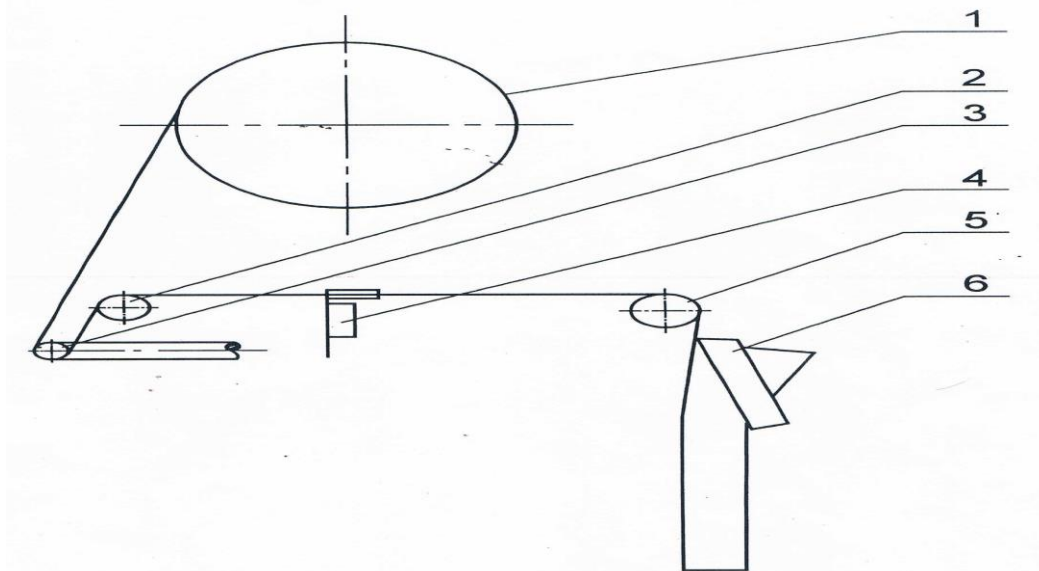

Figure 3、 putting on film schematic diagram

- 1、 packing film; 2、5、 guide roller; 3、 prestretching roller; 4、 photoelectric sensor;
6、 former

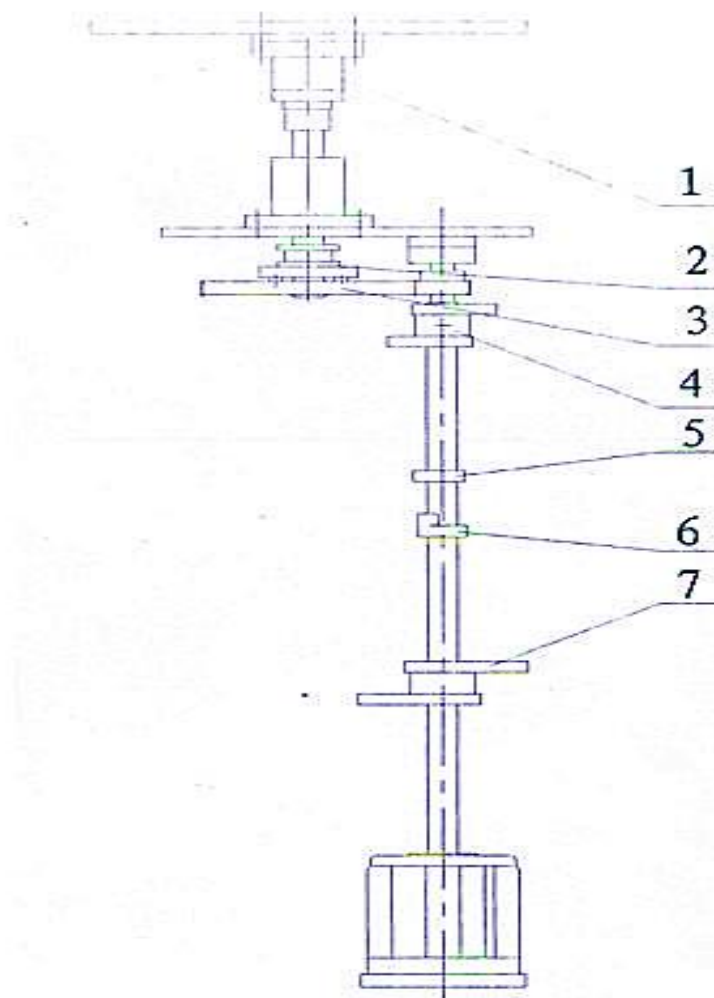

Figure 4

- 1、 adjust nut of measuring cup; 2、 clutch of wheel; 3、 filling adjust gear;
 4、 vertical sealing cam; 5、 bags' length cam; 6、 printing cam; 7、
 horizontal sealing cam

4. Operation and adjustment

(1)Ready for use

- 1)Machine should be wiped totally after unpacking, check whether the fastener is loose and wiring is loose or fall out, or electrical components is damaged. All moving parts inject lubricating oil (fat).
- 2) The machine should be reliable grounding, get through single-phase power supply of 220V/50Hz .
- 3) The width of the packaging material should be the same as the size of width guide groove of film former. Measuring cup inner cavity's size determines the volume of package, stuff filling amount need to be no more than around 70% of the volume of the bag , in order to prevent stuff to be sandwiched in the sealing surface in the process of packaging, affect the quality of heat sealing.

(2) Operation and adjustment

- 1)Connect with the power source, switch on the lock of power source, get through to the total power switch, computer monitor start to work.

- 2) The displays of temperature in micro-computer turn to the "On" position, set temperature of vertical sealing and horizontal sealing in temperature control instrument.
- 3) Open the vertical sealing, film wheel and horizontal sealing by pressuring jogging switch
- 4) Put the film to the packaging film former and the pulling film wheel passing through the guide roller (view figure 3).
- 5) Push the film and rotate the pulling wheel to make the film go down smoothly.
- 6) Put packaging film into the diaphragm between photoelectric head and guide plate, move photoelectric eye aim at color code on the wrapping film.
- 7) Enter the computer panel and start to operate. (detail information as aftermentioned)
8. Close the disc opener and adjust the feeding time. When the transverse sealing plate has just closed, the packaging is best filled in the bag. If the cutting time is inaccurate and the powder machine adjusts the cutting time, the granulator can open the turntable clutch. Its action is realized by the handle B in the drawing. Then the gear 3 connected with the feeding disc is lifted by hand. At this time, the turntable can be rotated to match the feeding time of the feeding gate with the packing process.
- 9) Put the packaging stuff into hopper, inflow the wheel, when photoelectric sensor detect that hopper are short of materials, start to vibrate for feeding stuff (there is no this device in KL-60L type), supply the stuff into the rotary tray
- 10) Adjust volume of the measuring cup, coincide with the requirements of the packaging, achieve it by rotating adjust nut of measuring cup 1 (view figure 4).
- 11) Start the main motor, the machines are ready for process of packaging and bag forming.
- 12) Check the sealing quality, according to the condition of sealing quality, adjust thermal sealing temperature and thermal sealing pressure.
- 13) Packing speed adjustment: after the machine running, rotate clockwise the ring of speed regulation of main motor pulley can slow down the packing speed, conversely the packing speed is faster.
- 14) While finished the packing process, open the stuff tray firstly; 2, Turn off the motor switch and totally switch, clean the machine after those.

5. Control panel instruction

I Main Technical Parameters

1.1 We take the newest generation of 5inch colorful touch screen, with a beautiful appearance and clear operation interface.

1.2 It can measure packaging length, without any measurement by hand, thus it saves adjustment time.

1.3 It has a color code localization function. Only by touching the screen slightly, you can move photoelectric eye instead of operating by hand.

- 1.4 It takes a special photoelectric catching and correction technology to improve photoelectric precision. Dark and shallow colors can be identified automatically instead of switching photoelectric eye.
- 1.5 Real-time monitoring of each function is convenient for inspection and maintenance.
- 1.6 It takes the method of angle adjustment to realize electric cam's function, so that feed and vibration cams and proximity switch is not needed any more.
- 1.7 Functions of Quantitative Alarm and Quantitative Stop
- 1.8 It has functions of no fill stop and no film stop.
- 1.9 It has localization stop function. When it stops, the seal cutter shall open to keep the film from scalding.
- 1.10 Touch the screen and you can realize adjustment of vibration time and forces.
- 1.11 The colorful touch screen is integrated with a controller, with a simple structure and less malfunctions.
- 1.12 The menu can be switched among languages of Chinese, English, Arabic and Russian and it is suitable internationally.
- 1.13 It can diagnose malfunctions intelligently and show error locations in Chinese (e.g. photoelectric error, timeout error, etc).
- 1.14 All controls are realized by software procedures and it is convenient to adjust functions and update technologies.
- 1.15 Main board is produced by SMT technology with a stable performance.

II Basic Operation of Touch Screen

This system takes colorful touch screen to show mechanical operation information and parameters, e.g. bag length, packaging speed and packaging quantity, etc. All visible information can be operated by touching. Only

touch the characters you want to know or revise slightly, the parameters shall show automatically, then you can begin related operations.

How to use the touch screen correctly?

1. Touch the screen by your forefinger or middle finger slightly, characters or pictures shall appear.
2. Touch the centre of character or picture as possible as you can.
3. Touch duration shall be 0.5~1.5s.
4. It's prohibited to touch screen with a sharp object, keeping from screen damaging.

III Automatic Running

Power on packaging machine, the followings shall be shown on the screen:

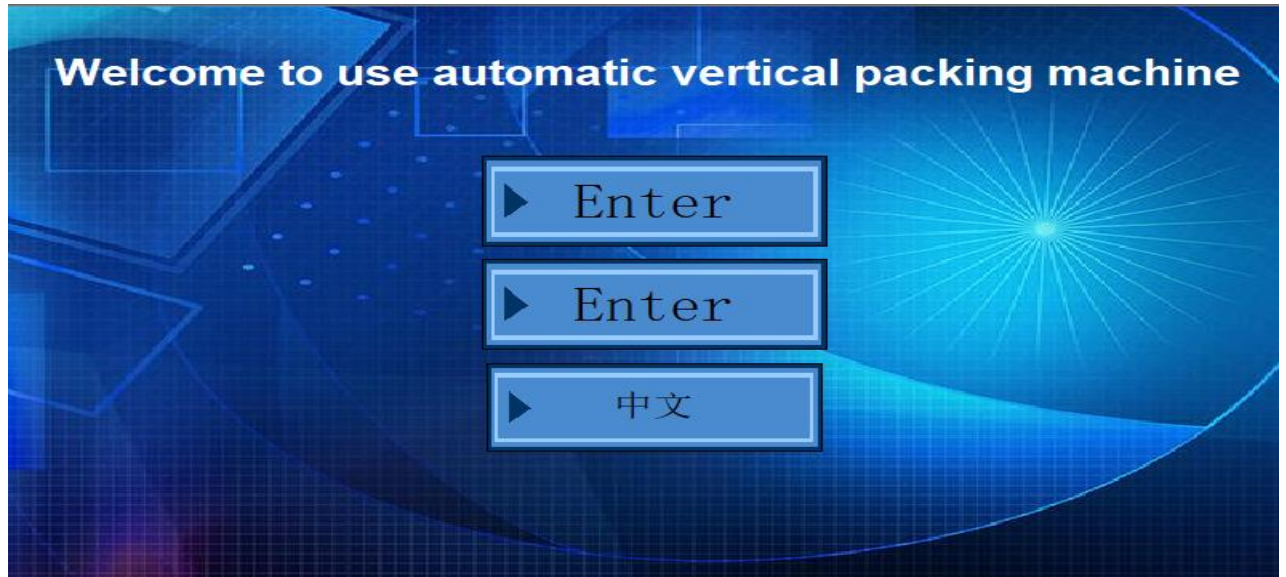

Click on  enter the operating interface. Before that, you can change the language.

Touch  and enter into “Run” interface as shown below:

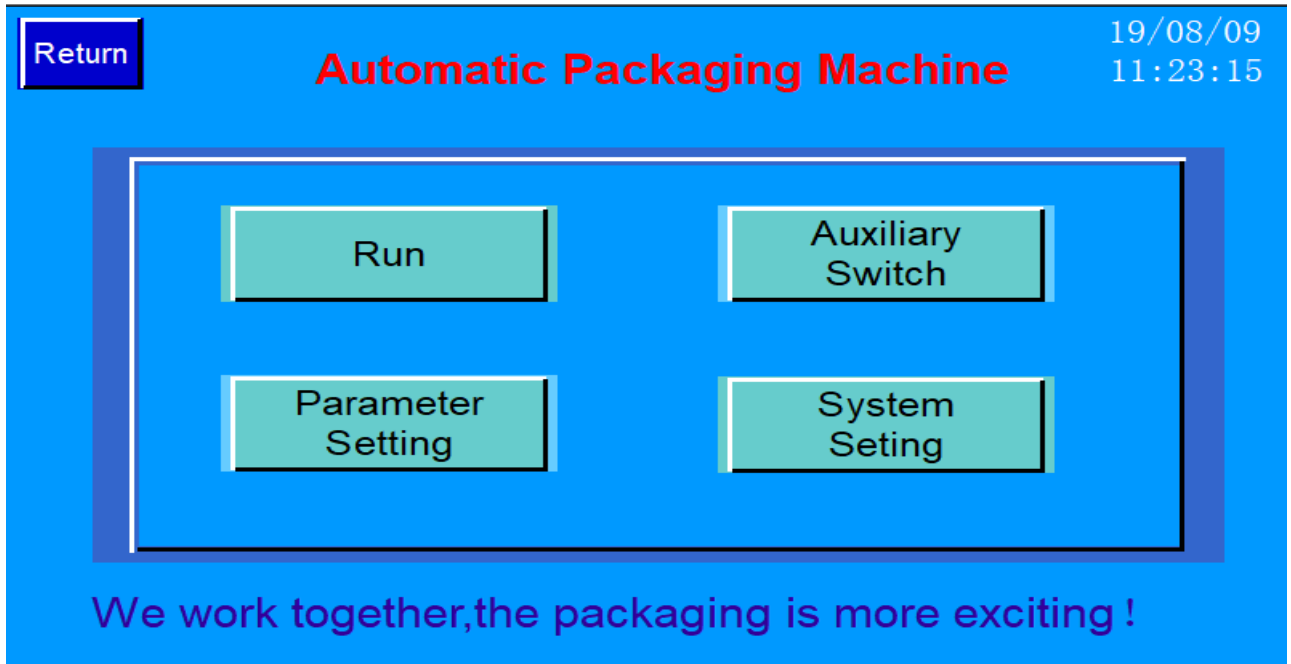

On this interface, some real time information such as weight, packing length, count, speed and status shall be shown and operations such as Run/Stop, JOG, Photoelectricity ON/OFF, Filling ON/OFF, Color location, Count, Length measurement and Return shall be realized.

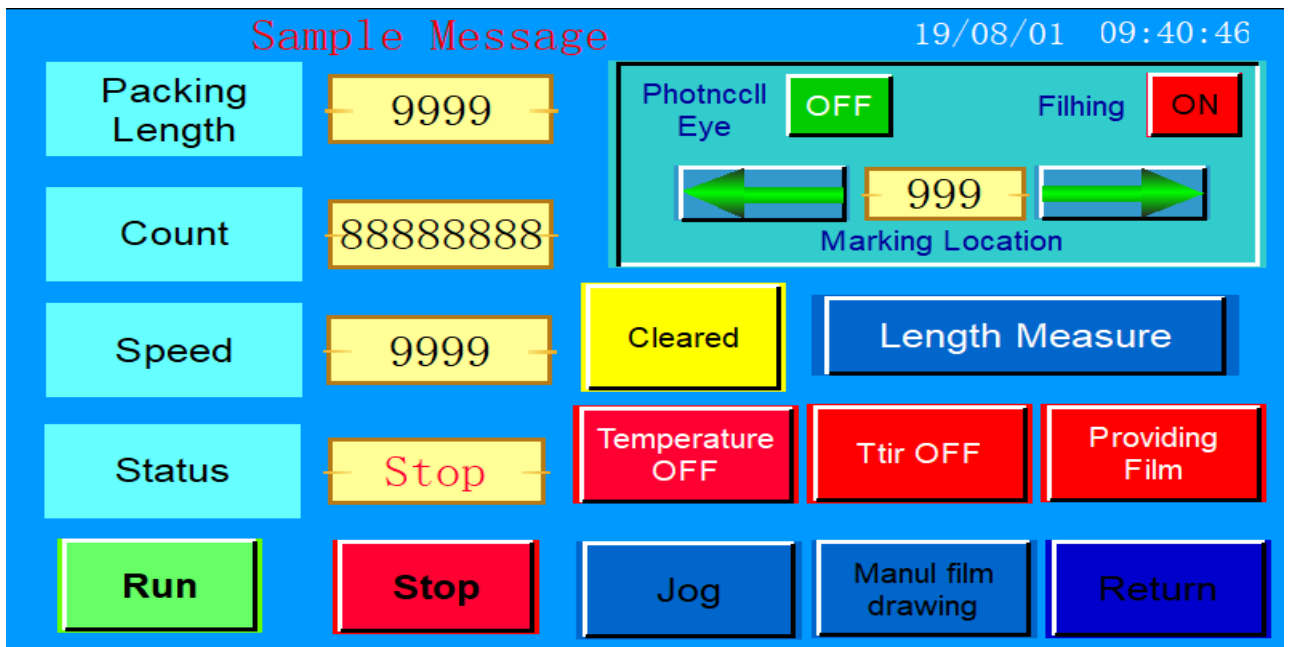



A fast operation method is provided as below:

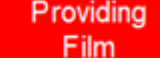

3.1 Touch **Run**, the packaging machine shall run. indicating the packaging machine is running. Click **Stop** to stop the machine. Then

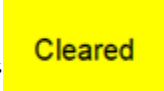
Count column starts to work and Speed column shows current packaging speed, thus you can know the production capacity per minute of this machine.

3.2    These three buttons correspond to three functional switches

3.3 If you need to restore the count to zero , “  ” **Note:** Cutting and quantitative stop also shall count from 0.

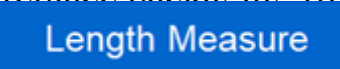
3.4  shows current work status of photoelectric eye. Touch this button, it shall change between “On” and “Off”. If color code is printed on film, make sure switch ON this button, otherwise, photoelectric following-up shall not be realized. This button is only used to close off photoelectric eye temporarily if adjustment is needed. During normal working, it’s better not to touch this button.

3.5 When replace packaging films in different lengths with color codes you can press  button, the computer shall measure the film length automatically when it starts, without inputting “Packing length” by hands. If the cutters didn’t cut on the color code, you can touch  button or  button to adjust cutting location and make sure the cutters cutting on color code properly.

3.6 During running, if stop is needed, please touch  button, the machine shall stop.

Important safety tips: please press “Stop” button (It usually is a red mushroom shape) on the machine, if in emergency, instead of touch  button on screen, because it takes shorter time to press “Stop” button on the machine.

3.7 Only in stop state, functions of “Manual film-drawing” and “JOG” in this page shall be effective and they are useful during machine adjustment. Touch **Manul film drawing** all the time, film-drawing motor shall work and the packaging film machine shall fill slowly. When other transmission mechanisms of the machine stop, move away your finger from the screen and the film-drawing motor shall stop.

3.8 "Machine Pointing" Click the button to run the main motor and open and close the knife.

3.9 “Filling” button: For powder machine with screw filling, open screw filling function

IV Parameter Setting

Touch **Parameter Setting**, the screen shall show the following information:

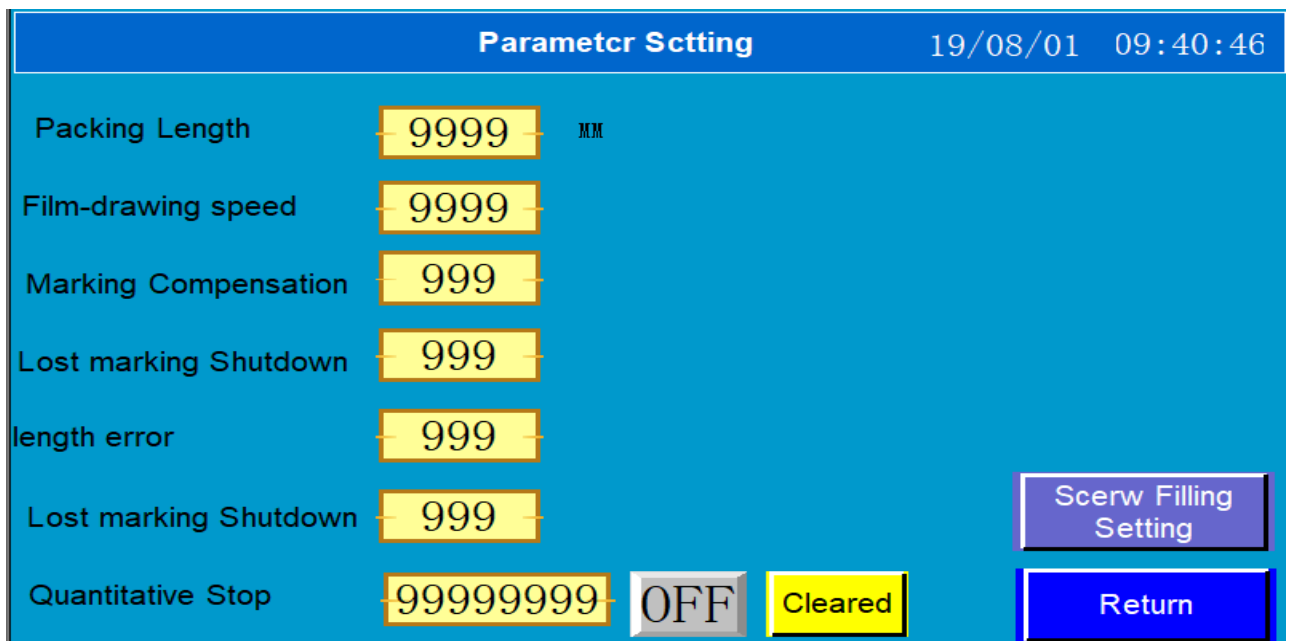

4.1 When packaging a new product for the first time, it needs to adjust the following parameters.

4.2 The black character under white background after each parameter name shows current parameter value, touch the column, a small numerical keyboard shall appear as below:

Touch numbers on the small numerical keyboard, you will get the needed parameter value, e.g. if you want to set “Packing length” to be 200, you need to touch three keys of 2-0-0, then press “Enter” , thus “Packing length” is revised to be 200.

When it needs to modify any input digit during inputting, please press to clear it off. If you don't want to save the input data, you can press “Quit” and leave the small keyboard.

4.3 Detail Parameter Meanings:

4.3.1 “Packing length” refers to the length of product bag which needs to be packaged, in a unit of millimeter (mm), e.g. input 200 for 200mm.

4.3.2 “Film-drawing speed” can adjust the speed of film-drawing machine and it is proper to follow up the packing speed of packaging machine. If slower, film-drawing shall be more successful; but if too slow, missing packaging shall appear.

4.3.3 "Mark Compensation" is used to adjust the position of cutting bags by continuing to pull the bags after the color label sensor senses the color label.

4.3.4 "Lost marking shutdown"

When the normal induction color label is not available, continue to work according to the set bag length, and stop after the specified period of work. During the specified period, the color label machine is sensed to continue working.

4.3.5 "length error", allowable color mark error, recommended to set to 5-8.

4.3.6 "Continuous dislocation shutdown"

The setting value is the number of times that the error of bag length exceeds the allowable deviation value, and the number of times reaches the machine shutdown.

4.3.7 "Quantitative shutdown" refers to the automatic alarm when the number of packages reaches the preset number, while the status bar shows "Quantitative alarm". When this parameter is set to 0, the function of "quantitative alarm" is invalid. When a batch of products only need to pack a certain quantity, the quantity of "quantitative alarm" can be set first. When the preset value is reached, the automatic shutdown (when the quantitative shutdown switch is set to be on) can be achieved, thus the artificial waiting time can be saved.

4.4 Touch "Screw filling setting" and enter into screw filling setting page, you can set parameters, e.g. filling weight, etc.

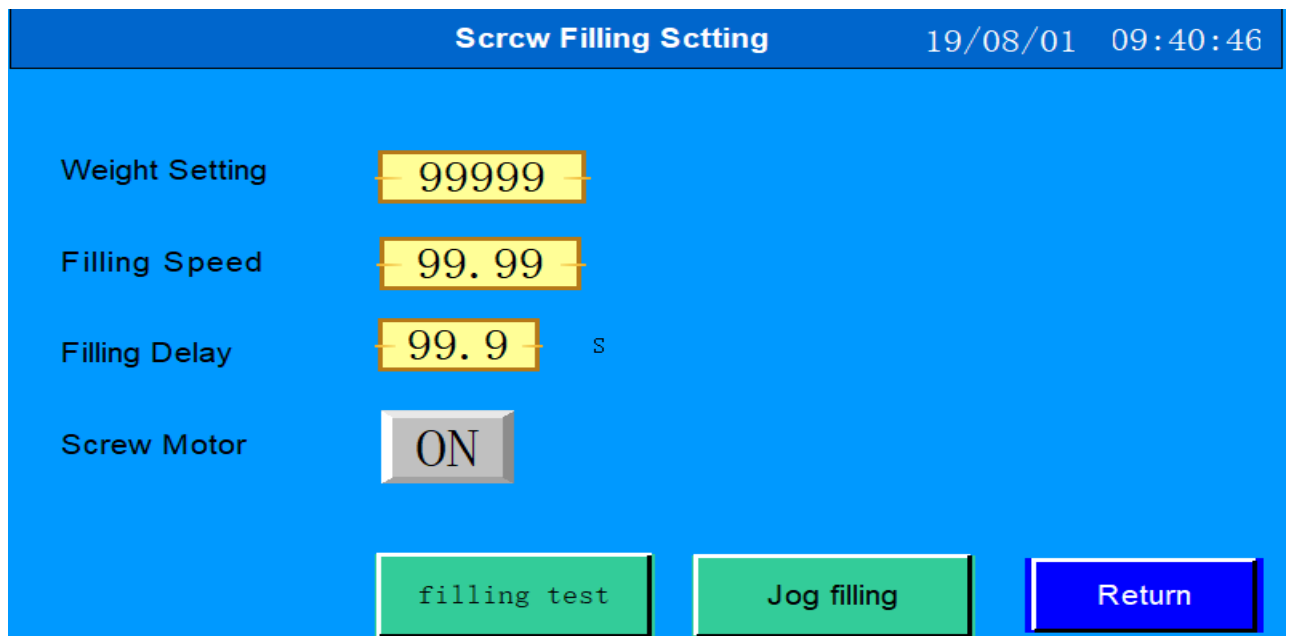

4.4.1 "Weight setting" means to set pulse quantity of screw motor actually, that is, the turns of screw motor, so as to adjust filling weight. Press "+" and "-" on the right for one time, the weight valve shall increase or decrease 1 and the weight can be finely tuned.

4.4.2“JOG filling”, press this key constantly, screw motor shall revolve slowly. Loosen it, the machine shall stop. This function shall be used to clear off the residue material from screw.

4.4.3 “Filling speed” is used to adjust the revolving speed of screw motor. If it is too fast, the torque of screw stepping motor shall become smaller and affect filling precision. It is proper to follow up the revolving speed of whole machine.

4.4.4 “Filling Delay” refers to the angle at which screw motor starts (that is when the screw motor begins to revolve). It is adjustable when proximity switch contacts at 0 degree or 300 degree. Normally, it is 90~220 degree.

4.4.5 “Screw motor switch”, refers to when it starts for a powder model machine and when it stops for a particle model machine。

4.4.6 "filling test": Run once according to the value set by weight.

V Auxiliary Switch

Touch **Auxiliary Switch**, the screen shall show the following pictures:

Auxiliary Switch		19/08/01 09:40:46	
Front vibrat Delay	<input type="text" value="99.9"/> s	Inflate Delay	<input type="text" value="99.9"/> s
Front vibrating time	<input type="text" value="99.9"/> s	Inflate time	<input type="text" value="99.9"/> s
Front vibrat power	<input type="text" value="9999"/> <input type="button" value="ON"/>		<input type="button" value="ON"/>
Back vibrat Delay	<input type="text" value="99.9"/> s	Delayed shutdown	<input type="text" value="99.9"/>
Back vibrating time	<input type="text" value="99.9"/> s	Srartop film-drawing	<input type="button" value="OFF"/>
Back vibrat power	<input type="text" value="9999"/> <input type="button" value="ON"/>		
<input type="button" value="Timing"/>		<input type="button" value="Return"/>	

5.1 "front vibrat Delay" adjusts the opening time of foreshock.

5.2 "front vibrating duration" adjusts the opening time of foreshock.

5.3 The "front vibrat power" regulates the vibration intensity.

5.4 When the mode of back vibrat is "timing" mode, the function is the same as that front vibrat . When the mode is changed to on-off mode, it only works when it receives external proximity switch signal, and stops working when it is not received. It is no longer controlled by " back vibrat delay" and " back vibrat time".

5.5 "inflate delay" adjusts the opening time of inflation.

5.6 "inflate time" adjusts the opening time of inflation.

5.7 "delayed shutdown" When the stop button is pressed, the machine will delay setting time and stop.

5.8 "srartop film-drawing" Start the machine, first stretch the length of a bag.

VI System Setting

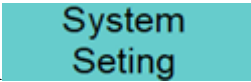
Touch , the screen shall show the following pictures:

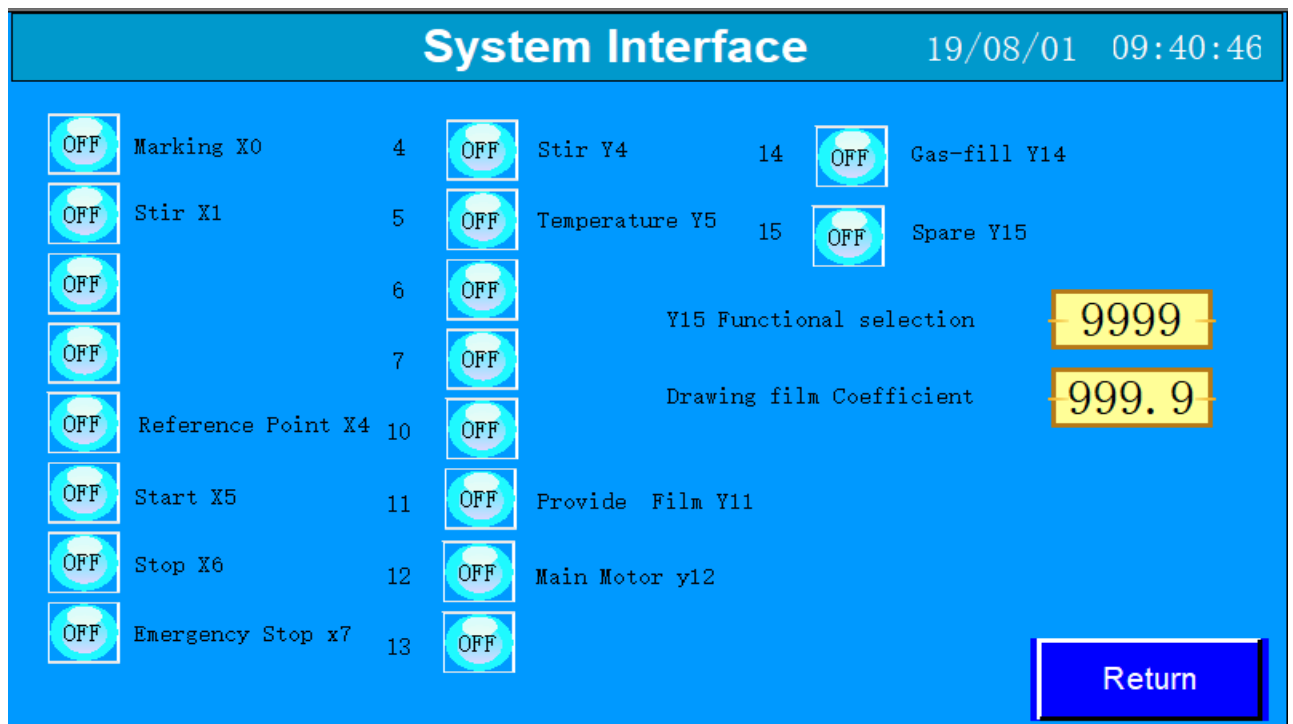

6.1 Y15 standby function point, select other function point number, can

replace the corresponding function point.

6.2 Roller coefficient, through adjusting the coefficient, the set bag length is consistent with the actual finished bag length.

VII Common Error Tips and Treatment

“Status” column in “Run” page shall show all states of packaging machine, e.g. when the following error tips appear, you can try to use the following methods to remove troubles:

“Status” column in “Run” page shall show all states of packaging machine, e.g. when the following error tips appear, you can try to use the following methods to remove troubles:

7.1 “Lost marking Shutdown”

①When status column shows “ “Lost marking Shutdown!” with “tick-tick-” alarming sound, please adjust the sensitivity of photoelectric eye. Too high or too low sensitivity of photoelectric eye shall cause malfunctions.

②Please set “Photo-electricity” to be OFF if color code is not printed on your bag.

7.2 “length error shutdown”

When status column shows ““length error shutdown” with “tick-tick-” alarming sound. Generally, the settings of bag length are totally inconsistent with the actual distance between the two markers, or the allowable deviation value is too small.

7.3 “Quantitative stop”

Malfunctions: Packaging machine shall stop and status column shall show

“Quantitative stop!” when a proper number of packaging work is finished.

Please confirm that whether you are using the function of “Quantitative

stop”. If not, please modify the value of quantitative stop in the page of

“Product parameters” to be 0 and set the “Quantitative stop” to be OFF, this

problem shall be resolved.

6: Temperature control instrument

1、Structure of panel

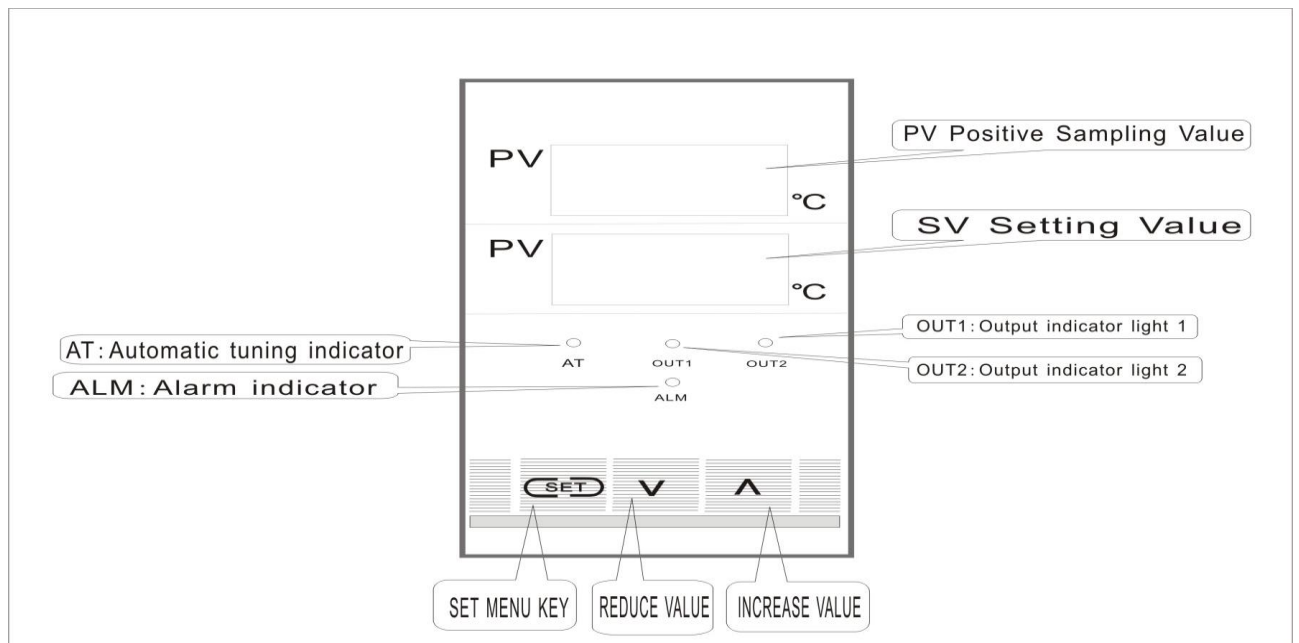

PV display window: Positive value (Sampling value) display window.

SV display window: setting value display window.

AT indicator: Auto-tuning indicator light , shine for automatic tuning status.

OUT 1 and OUT 2: control the output indicator light, shine for output status, extinguish for no output status.

SET: the setting schema transformation key.

2、Panel button operational guide

(1) SET button: in normal display status, short press the AT button to enter the SV modification status and SV value flashing; Long press the SET button to enter the Setting menu.

(2) “▲” and “▼” button: in the SV value menu or Setting menu, short press to set the values.

(3) In “▲” modifying SV status, long press this button can rapidly increase the SV value or menu parameter value.

(4) In “▼” modifying SV status, long press this button to quickly reduce the SV value or menu parameter value.

(5) After the completion of changing all parameters ,need to press SET to confirm.

7.Maintenance

1. Keep all the moving parts lubricating, and fill frequently the lubricating oil (fat). Keep reducer the height of oil level, once lack of oil, fill into G - N680W worm gear oil. Change the oil after 150-400 hours for new revolving, hereafter change oil for every 4000 hours.

2. Always keep the machine clean, in order to prevent foreign falling into the hot sealing plate or the gear and damage the parts.

3. Pay attention to machine rotating sound , check if the sound is harmonious, once hearing some noises of foreign body, ought to stop and check the machine immediately.

4. Electrical failure should be examined and repaired by professional and experienced electronic technical personnel.

5. Often keep the keenness of the cutter, if find that bag's kerf is not neat enough, replace the blade immediately.

Disclaimer: because of the continuous improvement of control system and software update of the different machines , there may be some different from above instruction in some individual actual operation, so understanding and forgive me!

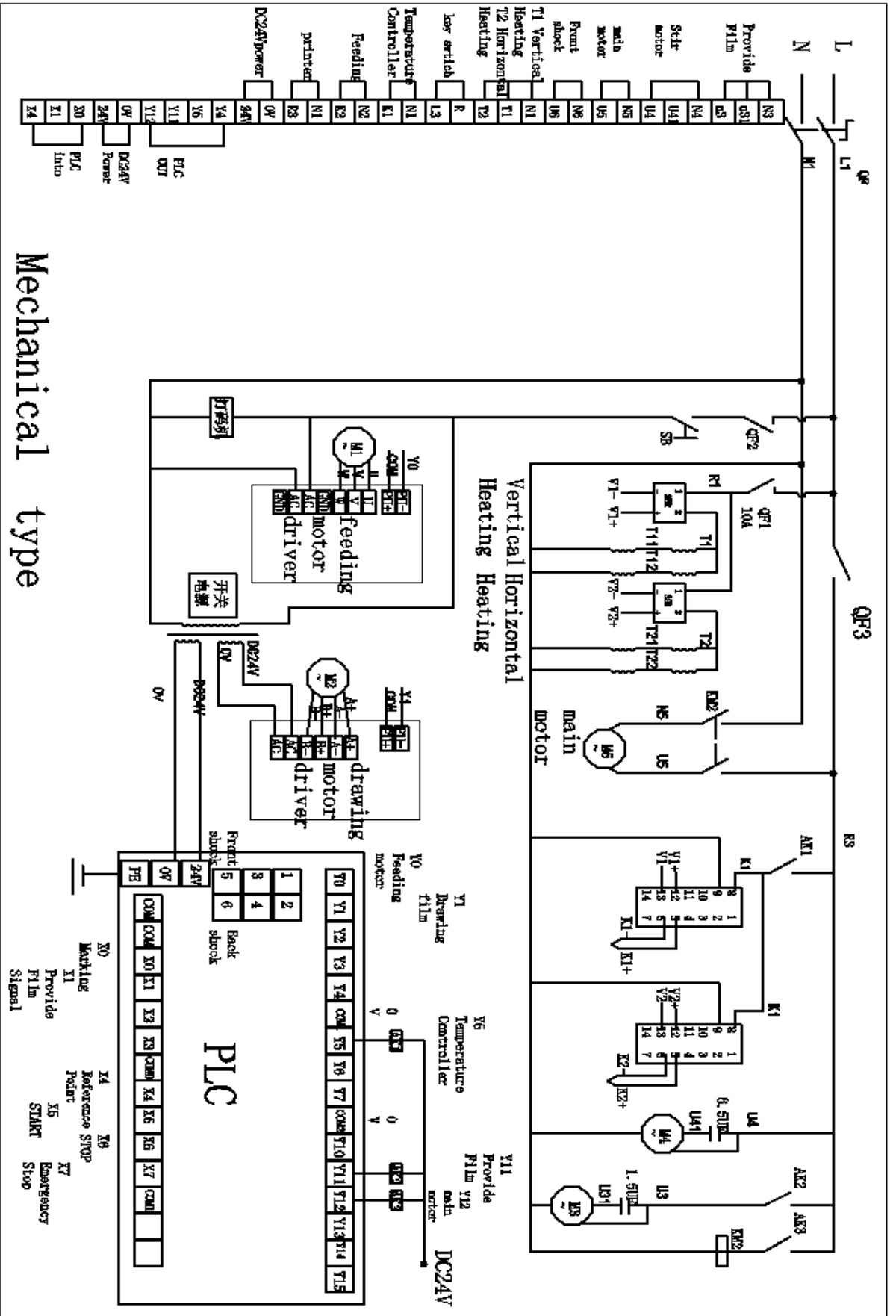

Mechanical type